

PARTS LIST		
ITEM	QTY	DESCRIPTION
(1)	1	AIMPOINT ACRO PLATE PN 01-009
(2)	2	#8-40, .278 SCREW

Tools Needed

- Torque wrench
- T10 Torx bit for installing Aimpoint ACRO
- T15 Torx bit for installing adapter plate

1. Install Adapter Plate

- Affix adapter plate (1) to Nightforce RAP-i / X-treme Duty MultiMount ring using screws (2). Torque to 25 in-lbs.

2. Install Aimpoint ACRO Sight

- With the ACRO recoil stop positioned in the recess, push the sight forward and tighten the locking bar screw.
- Tighten the locking bar screw until light resistance is encountered.
Proceed with another $\frac{1}{4}$ - $\frac{1}{2}$ turn until fully tightened (torque to ≤ 26 in-lbs).
- Retighten the locking bar screw after initial firing to ensure the sight is securely fastened.

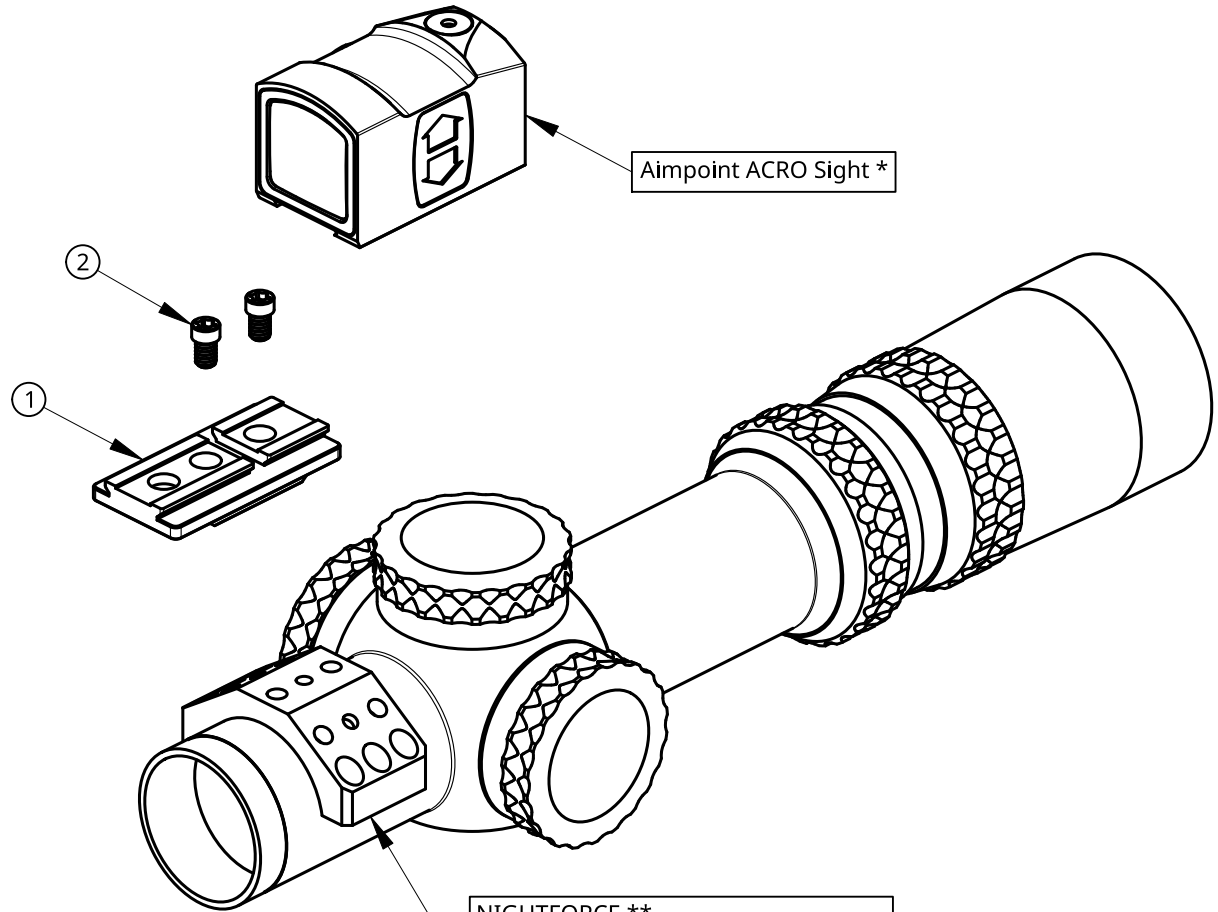

NIGHTFORCE **
 RAP-i / X-treme Duty MultiMount Ring
 - A425 (30mm)
 - A426 (34mm)
 - A687 / A689 (RAP-i, 30mm)
 - A686 / A688 (RAP-i, 34mm)

* Or other compatible sights with same mounting interface.
 E.g., Steiner MPS.

** Purchased separately.

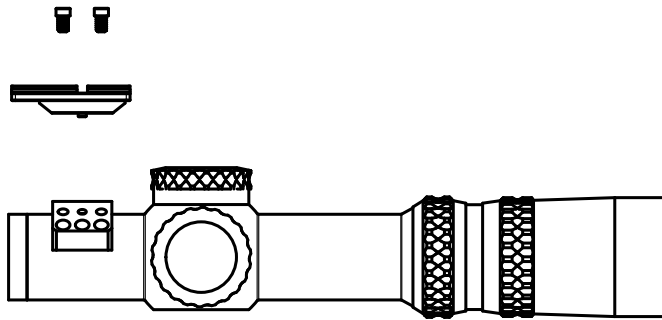

NAME		DATE								
DRAWN		KOENG.CO					01/18/2023			
CHECKED										
APPROVED										
MATERIAL				FINISH		SIZE		DWG NO.		REV.
6061-T6				Mil. Spec Type 3 Anodized		A		20230118		01
SCALE			WEIGHT		SHEET					
1:1.5			0.6 oz / 17 g		1 of 1					