

PARTS LIST		
ITEM	QTY	DESCRIPTION
(1)	1	HOLOSUN HE509T ADAPTER
(2)	2	#10-24, $\frac{3}{8}$ SCREW

Tools Needed

- Torque wrench
- $\frac{3}{32}$ Hex bit for torque wrench
- T10 Torx bit for torque wrench
- T15 Torx bit for torque wrench

1. Install Adapter Plate

- Affix adapter plate (1) to Badger Ordnance ARC using screws (2). Torque to 35 in-lbs.

2. Install Holosun HE509T Sight

- With the HE509T recoil stop positioned in the recess, push the sight forward and tighten the locking bar screw.
- Tighten the locking bar screw until light resistance is encountered.
Proceed with another $\frac{1}{4}$ - $\frac{1}{2}$ turn until fully tightened (torque to ≤ 19 in-lbs).
- Retighten the locking bar screw after initial firing to ensure sight is securely fastened.

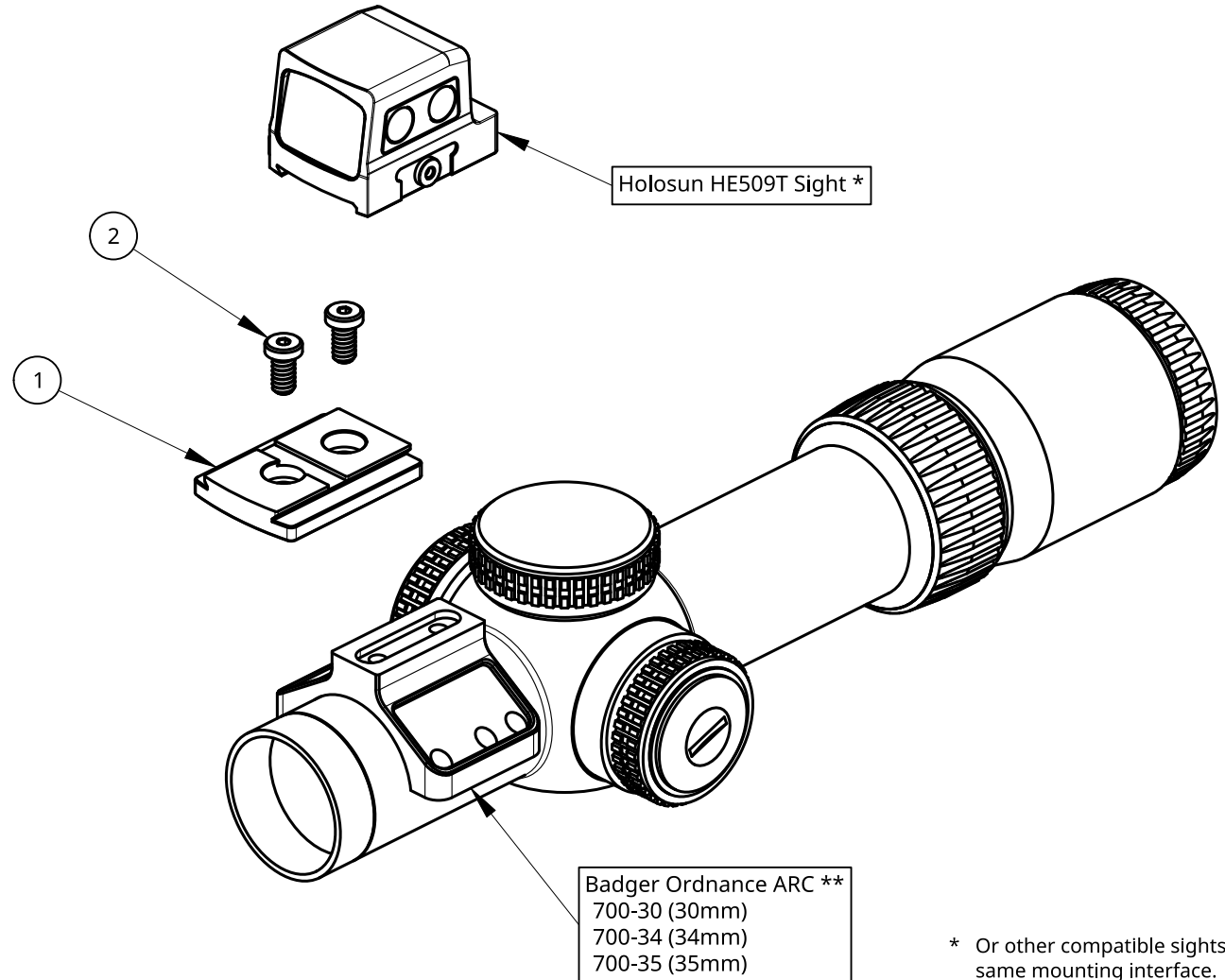

Badger Ordnance ARC **
700-30 (30mm)
700-34 (34mm)
700-35 (35mm)

* Or other compatible sights with same mounting interface.

** Purchased separately.

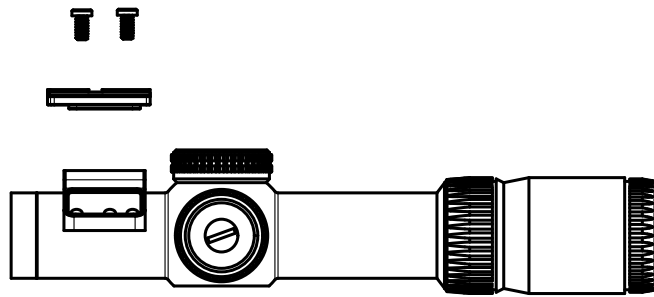

Find this document at: <https://koeng.co/instructions/>

DRAWN		NAME	DATE	 HE509T C1 ADAPTER PN 01-012		
CHECKED		KOENG.CO	03/31/2023			
APPROVED						
MATERIAL		FINISH	SIZE	DWG NO.	REV.	
6061-T6		Mil. Spec Type 3 Anodized	A	20230331	1	
SCALE		WEIGHT		SHEET		
1:1.5		16g / .6oz		1 of 1		