

Tools Needed

- Torque wrench
- 2.5mm Hex bit for installing the Aimpoint MICRO sight
- T15 Torx bit for installing the adapter

STEP 1. Install Aimpoint MICRO Sight

Fasten the Aimpoint MICRO sight to the adapter (1) with four screws (3).

If using an optional KOENG Aimpoint Micro Spacer (PN 01-020), use the longer screws included with the spacer kit instead.

Max torque 10 in-lbs ++.

STEP 2. Install Adapter

Affix the adapter (1) to Nightforce RAP-i / X-treme Duty MultiMount ring using four screws (2). Torque to 25 in-lbs.

++ Reference your red dot sight user manual for the proper torque value.

* Or other compatible sights with same mounting interface.
E.g., Sig Sauer ROMEO4T-PRO.

** Purchased separately.

PARTS LIST

ITEM	QTY	DESCRIPTION
(1)	1	AIMPOINT MICRO ADAPTER
(2)	4	#8-40, .28 SCREW
(3)	4	M3 x 5 SCREW

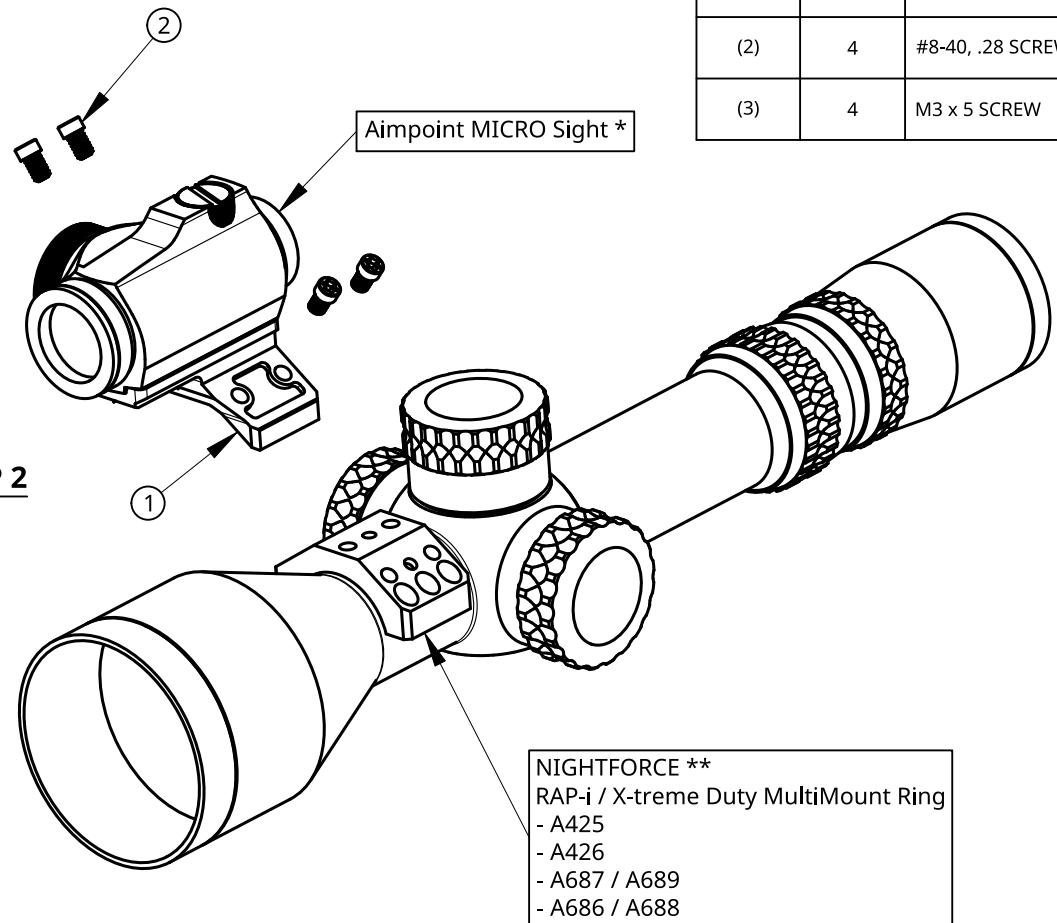

STEP 2

Aimpoint Micro Spacer **
KOENG PN 01-020
Includes four longer screws

NIGHTFORCE **
RAP-i / X-treme Duty MultiMount Ring
- A425
- A426
- A687 / A689
- A686 / A688

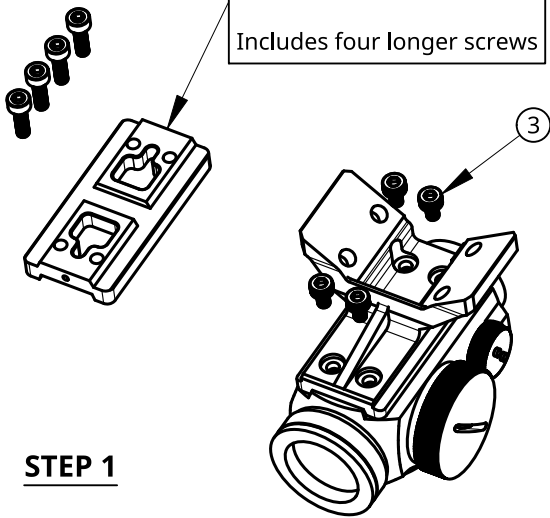

STEP 1

NAME		DATE		KOENG		
DRAWN		11/28/2023				
CHECKED				TITLE		
APPROVED				MICRO Nightforce Adapter		
				PN 01-018		
MATERIAL		FINISH		SIZE	DWG NO.	REV.
6061-T6		Mil. Spec Type 3 Anodized		A	20231128	01
SCALE		WEIGHT		SHEET		
1:2		24.1g / .85oz		1 of 1		