

PARTS LIST

ITEM	QTY	DESCRIPTION
(1)	1	AIMPOINT ACRO PLATE PN 01-009 REV02
(2)	2	#8-40, .278 SCREW

This document fits an 8.5 x 11 US Letter sheet.
Document directory: <https://koeng.co/instructions/>

Document directoryURL QR code:



* Or other compatible sights with same mounting interface.
E.g., Steiner MPS.
** Purchased separately.

Tools Needed

- Torque driver / wrench (e.g., 5 - 25 in-lbs).
- T10 Torx bit for installing Aimpoint ACRO.
- T15 Torx bit for installing the adapter plate.

1. Install Adapter Plate

- Affix adapter plate (1) to Nightforce RAP-i / X-treme Duty MultiMount ring using screws (2). + Torque to 25 in-lbs.

2. Install Aimpoint ACRO Sight

- With the ACRO recoil stop positioned in the recess, push the sight forward and tighten the locking bar screw.
- Tighten the locking bar screw until light resistance is encountered.
Proceed with another 1/4 - 1/2 turn until fully tightened (torque to <=26 in-lbs).
- Retighten the locking bar screw after initial firing to ensure the sight is securely fastened.

+ The MultiMount interface is machined to have a tight fit to help alleviate impact force from the mount screws and to enhance zero retention.

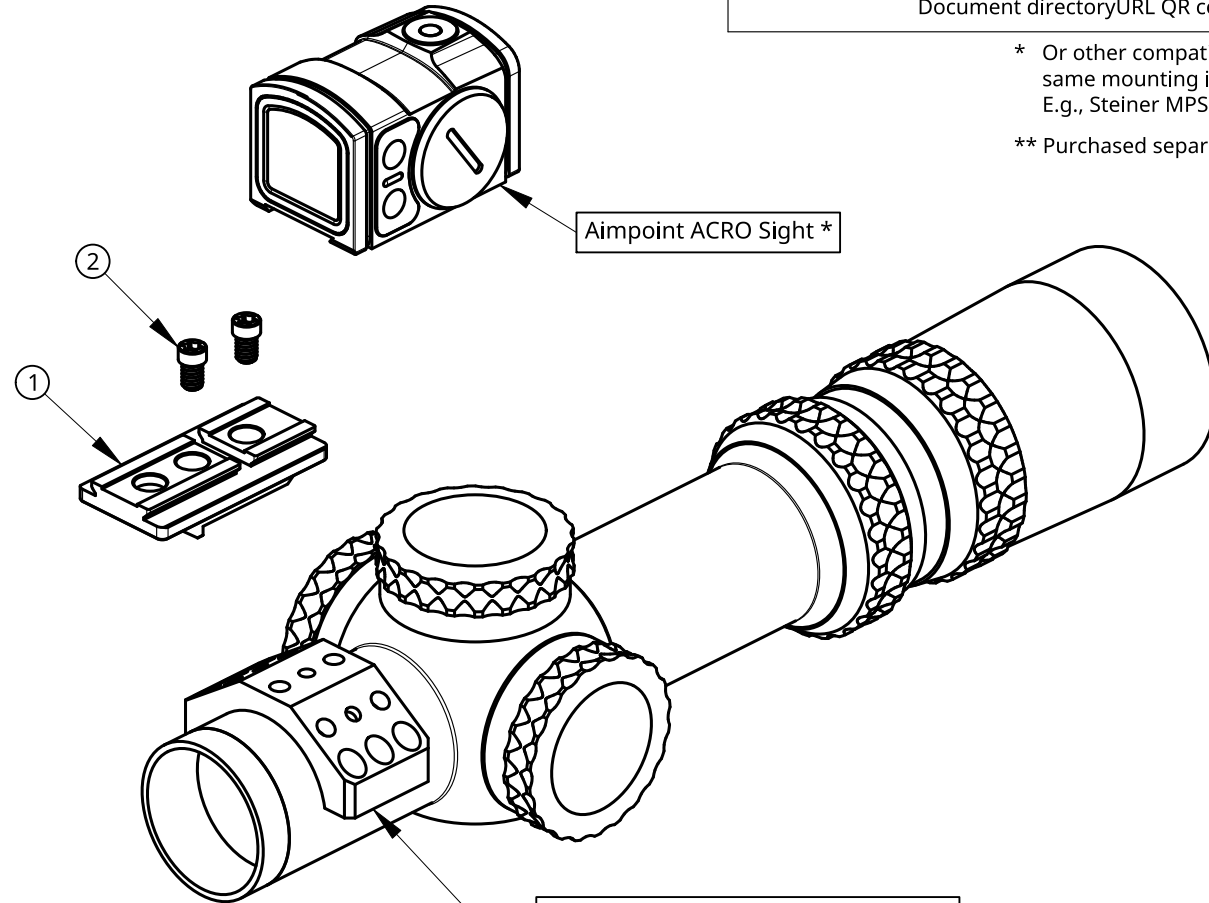

AR15 / M4 HEIGHT OVER BORES

w/ 1.54" SCOPE MOUNT
ATACR 1-8X: 2.74"
ACRO: 4.45"

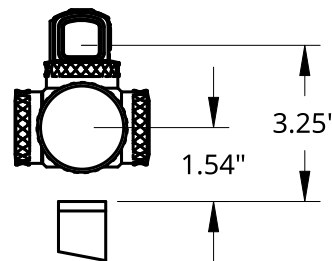
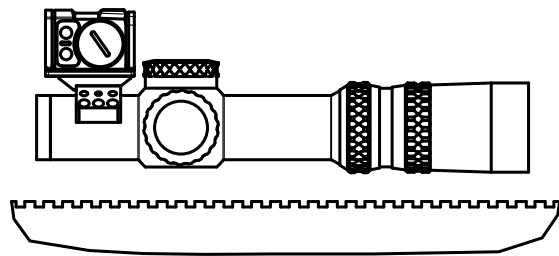

NIGHTFORCE **

RAP-i / X-treme Duty MultiMount Ring	
- A425	(30mm MultiMount)
- A426	(34mm MultiMount)
- A687 / A689	(RAP-i, 30mm)
- A686 / A688	(RAP-i, 34mm)

REPLACEMENT / OPTIONAL PARTS

ACRO NIGHTFORCE ADAPTER
PN 01-009 REV02



ADAPTER MOUNT SCREWS
PN 10-009



NAME	DATE
DRAWN	KOENG.CO 2024/09/10
CHECKED	
APPROVED	
MATERIAL	FINISH
6061-T6	Mil. Spec Type 3 Anodized

KOENG

TITLE: ACRO Nightforce Adapter
PN 01-009 REV02

SIZE: A DWG NO.: 20240910 REV.: 01

SCALE: 1:1.5 WEIGHT: 0.63 oz / 17.9 g SHEET: 1 of 1